



Research Article

ISSN : 0975-7384
CODEN(USA) : JCPRC5

The novel analysis model of cloud computing based on RFID internet of things

Yan Wang[#] and Xiao Wang[@]

[#]Center of Modern Education Technology, Xinxiang Medical University, Henan Xinxiang, China
[@]The Computer Center, Xinxiang Medical University, Henan Xinxiang, China

ABSTRACT

The Internet of things is through the radio frequency identification (RFID), infrared sensors, GPS, laser scanners and other information sensing device, as agreed in the agreement, any items and Internet connection, the exchange of information and communication, to realize intelligent identification, location, with a network tracking, monitoring and management. The core of cloud computing is the high-speed information processing and transmission, its core idea is that large amounts of computing resources connected by a network of unified management and scheduling, constitute a computing resource pool to users on demand service. The three components of RFID system include the reader, antenna and the tag. The paper put forward the novel analysis model of Cloud computing based on RFID Internet of things.

Keywords: Internet of things, RFID, Cloud computing.

INTRODUCTION

Internet of Things refers is to various information sensing equipment, and it is such as radio frequency identification (RFID) a huge network device, infrared sensors, global position system, laser scanner, gas sensors and other devices and Internet combined form. The purpose is to let all of the items are connected together; facilitate the identification, management and control. Can say, the Internet of things is the pan connected in network technology to build up object - based Internet, the connection may contain any time, any place and any connection object.

Sensing layer and the development of networking applications based primarily through radio frequency identification (RFID) system to achieve automatic collection of RFID tags and identification [1]. RFID tags attached to the items can be tracked, thereby achieving global circulation, perception and information system connected to an electronic code to read the label (Electronic Product Code EPC), and enter the network information system. IOT network layer will build on the existing mobile communication networks and the Internet, based on the perception layer collected upload data storage, query, analysis, mining, understanding and perception data based decision-making and behavior, and to achieve this series of data management and processing is the core EPC middleware, which acts as the network layer of things important part of the past and provide various services for the application layer basis.

Cloud computing refers to the IT infrastructure delivery and usage patterns, through the network to on-demand, easy extension ways to obtain needed resources; generalized cloud computing service delivery and usage patterns, through the network to on-demand, scalable way to obtain the desired service. This service can be IT and software, Internet, but also other services. The core idea of cloud computing, the computing resources connected by a network of unified management and scheduling, constitute a computing resource pool to users on demand service. Provide the resources of the network are called "cloud". "The cloud" resources can be extended indefinitely in the user's

view is, and you can access at any time, as needed, to expand, pay per use. Industrial grade three layered cloud: cloud software platform, cloud, cloud equipment.

The Internet of things is the Internet of connected things. This has two meanings: first, the core and foundation of the Internet of things is still the Internet, is the extension and expansion on the basis of Internet; second, the extension and expansion of the client to any goods and goods between, the exchange of information and communication. Cloud security through a large number of client network of software behavior in the network anomaly detection, to obtain up-to-date information, malicious Internet Trojan program, pushed to the Server end of the automatic analysis and processing, then the solution of virus and Trojan distributed to each client. The paper put forward the novel analysis model of Cloud computing based on RFID Internet of things.

1. Development Internet of Things based on RFID

The reader is the most important infrastructure, RFID system in one aspect, the weak electromagnetic signals RFID tag returns through the antenna RF module into the read write device is converted to digital signals, and then through the reader of the digital signal processing unit for processing plastic necessary for its, the demodulating returned from information, complete the RFID tags identification or read / write operations; on the other hand, upper layer middleware and application software and reader interact, realize the operation instruction execution and data upload.

The system has the advantages of simple structure, low technical difficulty, more in line with China's national conditions. The mobile is currently operating payment systems without major changes, only in the mobile payment platform on the increase in the RFID data support system and GPRS gateway can, can make full use of the existing resources of mobile network.

The Internet of things to a new generation of IT technology fully used in all walks of life, in particular, is the embedded sensors and equipment to the power grid, railway, bridge, tunnel, highway, building, water supply system, dam, oil and gas pipelines and other objects, and then the "Internet of things" and the Internet to integrate existing, implementation the integration of human society and the physical system, the integration of network, there are super powerful center computer group, to implement the management and control of the real-time integration within the network of personnel, machinery, equipment and infrastructure, on this basis, the human can manage the production and life in a more precise and dynamic way, reach "wisdom" state, improve resource utilization and productivity, improve the relationship between man and nature [2].

Based on the RFID design of the microprocessor, the key information may not contain any encryption in ROM, but it does contain enough I/O, access control, encryption programs, and other information, these destructive attacks in non vital. Therefore, for the use of microprocessor RFID design, recommended by the FLASH or EEPROM non-volatile memory stored procedures, as is shown by equation1.

$$k_i = \hat{k}_i / \sqrt{\sum_{i=1}^t \hat{k}_i^2} \quad (1)$$

Includes two kinds of antennas in RFID systems, a class is the RFID antenna on the label, because it has and RFID tags are integrated into a whole, so no separate discussion, another kind is the reader antenna, which can be built into the reader, RF can also write through coaxial cable and read the output port connected to. The use of integrated antenna transceiver separation technology is to realize the transmitting and receiving function. Importance of antenna in RFID system is often neglected by people, in the practical application; the design parameters of the antenna are the main factors affecting the RFID system identification range. High performance of the antenna not only has good impedance matching characteristics, also need according to the characteristics of application environment for directional properties, polarization and frequency characteristics of special design.

In this paper, by analyzing the mobile payment development present situation and combining with China's national conditions, puts forward the scheme of implementation and the overall framework for GPRS mobile payment system based on RFID technology [3]. Compared with the existing domestic mobile payment system, the system has the characteristics of high efficiency, convenient, reliable; at the same time, compared with other RFID based mobile payment system, more in line with China's national conditions, the system has the advantages of simple structure, make full use of existing resources and mobile network; taking into account is currently in the integrated test stage.

The Internet of things needs many sensors, this must have an infrastructure, such as paved roads, and this is the first

step. Distributed sensor, how to collect data, after collecting data how to manage, how search data, how to find the data structure analysis, this is the biggest problem. We now just put sensors in 'complex', do this step, but only the 'network', to form a complete network. The application of RFID end user interface, to assist the user to read and write instructions and the logic of the middleware setup, gradually transforms the RFID atomic events for business users can understand, and demonstrate the use of visual interface, as is shown by figure1.

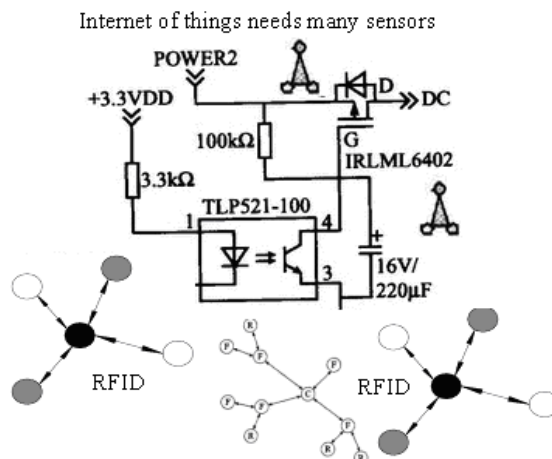

Fig. 1. Development Internet of Things based on RFID

Due to the current RFID standard is not unified, and the Chinese national standard has not yet issued, taking into account the mobile payment application characteristics of short distance, low cost: the frequency of 13.56MHz RFID technology. With reference to the frequency point: ISO/IEC 10536, ISO/IEC 15693, ISO/IEC 14443 TYPE A/B and ISO/IEC 18000-3. Two standard is widely applied at present is ISO/IEC 15693 and ISO/IEC 14443 TYPE A/B. ISO/IEC 15693 belongs to the loose coupling of RFID standard, the read range is about 0~1m, and is compatible with the ISO/IEC 18000-3 standard. But the communication rate is relatively low, the single side carrier at low 6.62kbits/s, high speed 26.48kbits/s; double subcarrier is respectively 6.67kbits/s and 26.69kbits/s.

Only when the read and write device, RFID can play its role. RFID reading and writing device with RFID card reader, RFID reader, RFID reader module, currently on the market the high price of CY-TZB-203, CY-TZB-208, YW-201 and YW-601U and YW-601R etc.. These devices can be RFID data read or write, and do good encryption. Long distance is CY-RFS-205; CY-RFS-209, WV-CID1500, and WV-VID1500 distance can be up to 1.5 kilometers.

One is the application layer, data processing, it covers every field of national economy and society, including electricity, medical, transportation, environmental protection, bank, logistics, industry, agriculture, city management, home furnishing life, its function can include payment, monitoring, security, location, inventory, forecast, for the government, enterprises, social organizations, individuals, families. This is the Internet as an important manifestation of depth information. Another is the terminal equipment layer, providing man-machine interface [4]. The Internet of things is "matter is net", but in the end is to people-oriented, operation and control or the needs of people, but here the man-machine interface has been far beyond human computer interaction concept, but refers to various kinds of equipment and people with the application with the interaction is shown by equation2.

$$H = [u_1 \ u_2] \cdot \text{diag}(\lambda_1, \lambda_2) \cdot [u_1 \ u_2]^T \quad (2)$$

RFID power consumption is an important issue in the process of chip design, the series solution of higher efficiency, more suitable for integrated circuit design. But in terms of security, the parallel scheme is a more ideal choice: the parallel discharge circuit will change the power supply ripple amplitude and control in the smallest possible range, making the supply current consumption fluctuation suppression in after the rectifier circuit. The AC signal can not reflect such antennas at both ends of any internal base band system (mainly is the microprocessor) state difference.

The RFID system at least comprises two parts of the electronic tag and reader. RFID readers (Reader) for wireless communication through the antenna and RFID tag, can achieve a write operation to the tag identification codes and memory data read or. The typical reader contains a high frequency module (transmitter and receiver), the control unit and the reader antenna. RFID read and write can be roughly divided into the following several low-frequency reader, high-frequency reader, UHF reader, dual frequency reader, the 433MHz active reader. The working principle

of RFID: radio frequency identification system, electronic label also known as radio frequency tags, transponder, data carrier; the reader is also known as the readout device, scanner, communicator, reader (depending on whether the wireless electronic tag can overwrite data).

For a general sense of the IC industry chain, to the bad chips on the wafer testing stage removed to reduce unnecessary waste of the back-end processing, RFID chip is no exception. According to the RFID for a general sense of the IC industry chain, to the bad chips on the wafer testing stage removed to reduce unnecessary waste of the back-end processing, RFID chip is no exception. According to the characteristics of RFID chip, wafer testing include: RF performance testing, function testing and memory test. As with ordinary chips, if with the help of chip function to test logic and memory chip, the test will substantially increase the cost of. Usually adopt the principle of equivalent test design test state additional to quickly finish. Because the test state provides fast, comprehensive access to the memory mechanism, it is necessary to complete the on wafer testing, the testing state permanently closed.

RFID ultra high frequency (UHF) tags for electromagnetic inverse scattering (Backscatter) characteristics, the metal (Metal) and liquid (Liquid) and other environmental sensitive, can lead to passive tag the working frequency (Passive tag) to the metal surfaces or liquid environment for work, but these problems with the development of technology has been fully resolved, for example, (SONTEC) label company that developed can well read application of passive tags in metal or liquid environment, to facilitate the deployment of RFID in the environment or application case.

$$f(x) = \frac{1}{2\delta^2} e^{-\frac{(x - \overline{m}_y)^2}{2\delta^2}} \quad (3)$$

Internet of things networking by communication layered system architecture, including perceptual extension system, transmission system, operation management system and a variety of applications, support different communication protocols at different levels [5]. Power system (MEMS) system on chip (SOC), the rapid development of technology, wireless communication and low power embedded, bred a wireless sensor network (Wireless Sensor Networks, WSN), and its low power consumption, low cost, distributed and self-organization characteristics has brought a revolution in information perception. Wireless sensor network is deployed in the monitoring area by the large number of cheap micro sensor nodes, through wireless communication to form a multi hop ad hoc network.

RFID Tag Package Technology and equipment: such as packaging technology based on low temperature hot pressing, optimization design of precision mechanism, multi physical quantity detection and control, high speed and high precision motion control, equipment fault diagnosis and repair, as well as online detection technology. The RFID tag integration: matching techniques such as between the chip and the antenna and special material attached to the three party, the label processing consistency technology etc.. Reader: such as dense reader technology, anti-interference technology, low cost and miniaturization reader integration technology, as well as the reader security authentication technology.

$$\begin{aligned} x' &= \frac{a_1x + a_2y + a_3}{a_7x + a_8y + 1} \\ y' &= \frac{a_4x + a_5y + a_6}{a_7x + a_8y + 1} \end{aligned} \quad (4)$$

RFID middleware plays a mediating role between RFID hardware and the application program, a set of general application program interface provided by the application program can use middleware (API), which can realize the connection to the RFID reader. In this way, even if the storage RFID tag data database software or back-end application increase or by other software or replaced, read and write RFID reader types increase occurs, the application end without modification can also handle, solve the many to many connection maintenance complexity.

The RFID tag by coupling components and chips, each label is the only electronic coding, attached to the object on the target object. The package can have different forms, such as the common form of credit cards and small round form etc.. From the energy point of view, the label can be divided into two types: passive tags and active tags. Passive tags itself with no power, when reading device to read on the label, energy generation antenna emits radio contact to RFID label, its light weight, small volume, life can be very long, but the transmission distance is limited. Active tags the battery energy, the identification distance is long, but its high price and short service life.

3. Research of Cloud Computing based on RFID

Cloud computing platform provides basic operating environment EPC application services and middleware system; meet the definition of service, the three aspects of service management and service call request [6]. Define the running environment of service support; the user can service definition to meet business needs. Service management major provides for assembly, service choreography, regulatory and other functions, to meet the definition of a particular business process. While the service calls for service calls the user provided unified interface, convenient for the user to use cloud computing platform service. But in the use of complex enterprise, cloud computing, and not very good software architecture. In essence, in the abstract level, service is located in the middle of business and technology.

Service oriented software architecture design one must understand the dynamic relationship between business requirements and can provide services, on the other hand, also want to understand the relationship between service and providing the services of the underlying technology.

$$u'(x_1, x_2) = \sum_{s=-n}^n \sum_{t=-n}^n w(s, t) u(x_1 + s, x_2 + t) \quad (5)$$

The core of cloud computing is the high-speed information processing and transmission, its core idea is that large amounts of computing resources connected by a network of unified management and scheduling, constitute a computing resource pool to users on demand service. Simply put, the transmission network information in real time is something the reality of the existence of the real-time information, and the cloud computing more virtualization, which usually via the Internet provides dynamically scalable and often virtualized resources.

RFID tags are commonly known as electronic tags, also known as the transponder (tag, transponder, responder), according to the working mode can be divided into active and passive (You Yuan) (Wu Yuan) two categories, this paper mainly studies the passive RFID tag and system. Passive RFID tag consists of tags and tag antenna or coil, realize the communication between the reader and the use of inductive coupling or electromagnetic backscatter coupling principle.

Radio frequency label information written by wired contact mode, generally called the label information into the device programmer. The ability to tag information to the contact type usually has repeatedly rewriting [7]. For example, in the written lorry tag information use is this way. Tags in the complete information after injection, usually need to write entrance closed up, in order to meet the application on the moisture-proof, waterproof, anti fouling and other requirements.

The upload data, the reader will RFID tag for atomic events to filter or a simple filter conditions, the processing for the reader the event after the upload, data exchange between the flow to reduce and middleware and application software, therefore also integrated microprocessor and embedded system in many reader, the part of the middleware functions, such as signal state control, parity error checking and correction. Future reader presents intelligent, miniaturization and integration trend, will also have the front control more powerful, such as direct and other industrial equipment field interaction even as the controller for on-line scheduling.

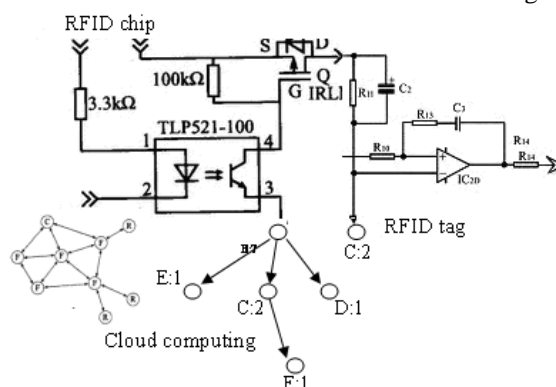

Fig. 2. The structure of Cloud Computing based on RFID

Cloud computing operating system, also known as cloud computing center, cloud operating system OS, is the whole management system of cloud computing data center (some people think that cloud computing system comprises a

cloud terminal operating system, all kinds of mobile phone operating system, such as the now popular little difference between single machine, operating system and the first do not do here discussion), it refers to the frame on the server, storage, network and other hardware resources and single operating system, middleware, database based software management huge basic hardware, soft resources on the cloud platform of integrated management system.

Cloud computing is a computing model based on the Internet, the remote data center, tens of thousands of computer and server connected to a computer cloud. Therefore, cloud computing can even let you experience the 10 trillion times per second computing power, have so strong power can be simulated nuclear explosion, forecast and market development trend of climate change. User's access data center computer, laptop, mobile phone etc, operate according to their own needs.

In the use of microprocessor RFID, also need to consider the software designers to improve code efficiency abuse CPU components (such as the address counter) safety problems caused by the behavior of the. The program counter for each instruction cycle auto increment, if be used for reading and writing memory address generator, attack only prevent processors to implement JUMP, CALL and RETURN instructions disturb the reading order can be normal. That is slightly with laser cutting some circuit connection; change the instruction decoder, the program counter circuit can realize the full access to memory.

$$K_N(x) = (2\pi)^{-d/2} \exp\left(-\frac{1}{2}\|x\|^2\right) \quad (6)$$

Cloud computing refers to the delivery of services and the use mode, refers to the network to on-demand, scalable way to obtain the desired service. This service can be IT and software, related to the Internet, or any other service. This pool of resources is called "cloud". "Cloud" is a virtual computing resources can be self maintenance and management, usually for some large-scale server cluster, including the calculation of servers, storage servers, broadband resources etc.. Cloud computing will all the computing resources together, and realized by software automatic control, without human involvement [8]. This makes the application provider does not need to worry about trivial details, to be more focused on their own business, is conducive to innovation and cost reduction.

4. The novel analysis model of Cloud computing based on RFID Internet of things

This paper presents a computing platform cloud based RFID network architecture, the operator can compute platform abstraction computation and storage resources by using cloud, integration middleware services, dynamic allocation to require the use of the user or the application, development business applications need according to the standard application program interface call resources required for the on the cost, with the total amount of use of resources is proportional to the throughput of the system rather than a check than. So the user can only care of the business logic implementation, operators can deploy various applications and services to the cloud computing platform and platform through the cloud computing control panel or interface provides application service.

In a simple RFID system, combined with existing network technology, database technology, middleware technology, to build a network consisting of a large number of readers and numerous mobile label, larger things become the development trend of RFID technology than Internet [9]. The Internet of things is widely used in many fields, in intelligent transportation, environmental protection, the work of the government, public security, security, intelligent home furnishing fire, industrial monitoring, elderly care, personal health etc.

$$\begin{aligned} \mu_m(\alpha(k) | \mathcal{R}_k) &:= \sum_{k \in \mathcal{R}_k} p(k) s_0(k) \beta(k) + \alpha(k) \\ &= \beta \mu_{s_0} + \alpha \end{aligned} \quad (7)$$

Cloud computing has three levels, the first is the infrastructure as a service (IAAS), is mainly responsible for communications, computing, storage and other infrastructure capacity; the two platform as a service (PAAS), is mainly responsible for development platform; the three is the software as a service (SAAS), is mainly responsible for providing application and software services. In order to realize the application of "cloud computing", first of all need to develop the industrial chain, this has to go through a very long process; second, many new technical backing, for support, business model can be fully established.

Cloud computing is equivalent to the next Internet; also some people said that the Internet of things is equivalent to the next Internet, even bigger than the current internet. But in fact, want to do like the Internet now so fire, even bigger than the Internet now, also need a very long time to. Cloud computing and the Internet of things will be

integrated, the Internet of things is extended to an angle of the material world, cloud computing is the processing, management, decision-making background is responsible for the Internet of things collected information processing platform, both need to combine.

These data need to be gathered to a certain storage and processing facilities through the wireless sensor network, broadband Internet, and the use of cloud computing to carry these tasks have very significant price advantage; from the quality perspective, the use of cloud computing facilities in the data processing, analysis, mining, can be more rapid, accurate, intelligent of the physical world management and control, so that people can more timely, fine management of the physical world, so as to achieve the "wisdom" of the state, greatly improve the utilization rate of resources and the level of social productive forces. It can be seen by Figure3, the cloud computing cost performance with its powerful processing capability, storage capability and high ratio, naturally become the network support platform.

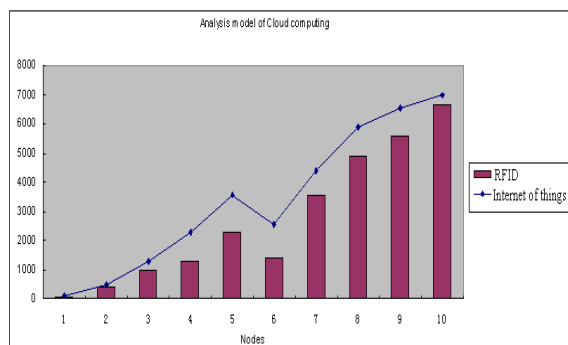

Fig. 3. Comparison novel analysis model of Cloud computing based on RFID with Internet of things

The emergence of cloud computing will have a revolutionary impact on the future development of IT industry and information industry. It will be centralized to decentralized, management ability, revolutionizing business ecosystem. Cloud computing and cloud on both sides of the traditional model of end it has incomparable advantage, provide more services for internal developers and business users in the cloud side, enhance the usage efficiency of infrastructure and resources deployment flexibility. In the end, the ability to rapidly deploy applications and services, and it is according to need to adjust the service volume. From the successful case of the current cloud computing can be seen in this technology greatly improves the performance of the Internet information technology, has the huge computation and memory cost advantage, make the IT resources and capacity configuration like utilities as required, convenient use, low price. China Mobile has the world's largest user data warehouse.

CONCLUSION

Sensors on the content networking acquisition timing information needs to be transmitted through the network, because of its large and huge, forming a mass of information, in the process of transmission, in order to ensure the accuracy and timeliness of data, must adapt to a variety of heterogeneous networks and protocols. Also, the Internet of things not only provides the connection of the sensor, it's also has the ability to implement the intelligent processing, intelligent control of objects. The Internet of things sensor and intelligent processing combination, the use of cloud computing, pattern recognition and intelligent technology, expand its application areas. Information obtained from the sensors in the analysis, processing and handling of meaningful data, in order to adapt to different needs of users not, find new applications and application mode.

The paper put forward the novel analysis model of Cloud computing based on RFID Internet of things. RFID tag stores a unique code to mark the reality of objects, the business process related information stored in a data container, when the code is used as the query value to obtain relevant information through the network. RFID technology can also identify multiple tags, fast recognition speed, combined with Internet technology, can realize the information sharing in the global range.

REFERENCES

- [1] YANG Zhexi, XUE Huacheng, *IJACT*, **2013**, 5(3), 282-289.
- [2] Bing Li, A Meina Song, Junde Song, *AISS*, **2012**,4(5), 283-291.
- [3] Zhang Qing-hui, Cheng Heng-feng, Xu Hong, *IJACT*, **2011**, 3(10), 9-14.
- [4]. Kai-jian Liang, Quan Liang, *AISS*, **2012**, 4(17),174 - 182.,

- [5] Qunfa Cui, Yanwei Tian and Hejun Yao. *Journal of Chemical and Pharmaceutical Research* ,**2014**,6(1), 394-401.
- [6]. Haiyan Liu, Jiahua Wei, Zenggang Xiong, Guangqian Wang, *AISS*, **2012**, 4(23), 531-539.
- [7]Sunong Wu, *AISS*, **2012**, 4(22), 690-697.
- [8]Guo Wang, Dong Dai, *JCIT*, **2013**, 8(4), 618 - 626.
- [9]Bi Tian Shu, Chen Jin Meng and Sun Meng. *Journal of Chemical and Pharmaceutical Research*, **2013**, 5(12), 612-618.