



Research Article

ISSN : 0975-7384
CODEN(USA) : JCPRC5

The construction of college student's satisfaction model based on structural equation model

Shuxin Guo*¹, Fei Teng¹, Jiannan Guo² and Yang Sun³

¹Management Science and Information Engineering College, Jilin University of Finance and Economics, Changchun, P.R. China

²Changchun School of Anda, Chanchun, P.R. China

³Industrial and Commercial Bank of China branch of Jilin Province, Chanchun, P.R. China

ABSTRACT

Structural equation model integrate factor analysis and path analysis of two mainstream model. Relationship has reserved variables for information complete and the processing of direct effect and indirect effect. Reflect more accurately of the real situation. In view of the student satisfaction important meaning for promoting higher education in china, this article carries on the questionnaire survey of 300 college students. According to the structural equation model about customer satisfaction evaluation model is established for the college student satisfaction model and the potential effects of factors on student satisfaction change was analyzed. The experiment data obtained shows that the data of satisfaction model presented in this paper is the same as what gotten from people software testing center. Therefore, college student satisfaction model based on structural equation model has a strong practical value.,which has a broad prospect.

Keywords: Structural equation model; higher education; student satisfaction; influencing factors

INTRODUCTION

With the popularization of higher education in our country the deepening of the process, the improvement of college enrollment rate. To enter a university, is no longer remote. And from elite education to mass education. Dispersion tend to form the power of teachers. Insufficient hardware devices. With the ideal university life in stark contrast. The pessimistic atmosphere. The school life is "teacher oriented" to "student self-learning" model. Studies of not smooth also brings to university life sense of loss. College students as the country force. To improve university student satisfaction not only can improve the quality of teaching is also related to the hope of the nation. So the study of college students satisfaction is important.

Research in recent years for college students' satisfaction has been an important topic of research Chinese education development and trend has already obtained many research results. Methods such as the Zhang Jie through factor analysis of college students on campus life satisfaction machine factors were analyzed[1]. The school should pay more attention to the students' mental health[1]. Zhao Lin through the study type on the quality of higher education institutions of regional differences[2]. Points out that ascribed factors influencing factors of education process to the education of students receiving and school satisfaction than students. Lu Genshu through the questionnaire in the form of 1500 college students across the country about the learning experience, learning and teaching quality satisfaction surveys[3]. The present study methods to improve teaching quality should be changed . Obtein the method of optimizing the teaching means.

Based on the collected 300 college students about the satisfaction questionnaire analysis. The students' expectation, perceived quality, student satisfaction, structural equation model student loyalty four latent variables. On the factors affecting the students' satisfaction and loyalty are analyzed.

Structural equation model and its principle

Structural equation modeling, Also known as covariance matrix model. Joreskog put forward the concept model of LISRET, the integration of the factor analysis and path analysis of two mainstream model[4]. As compared with the traditional statistics, with structural equation model to complete the information retained variables. Can deal with the relationship between the direct effect and indirect effect. Therefore, to tackle the same problem. Structural equation model can more accurately reflect the real situation. In recent years, structural equation model because of its special advantages are widely used in education, management, economic and other fields.

1. The concept of structural equation model

Structural equation model according to whether the variables can be observed directly. The variables are divided into two categories: latent variable and measurable variables. Latent variable is not directly observable variables. Such as satisfaction, work pressure, attitude. Measurable variables can be directly observed variables. Such as student achievement, income, price. According to whether the other variables. Variables are divided into endogenous and exogenous variables. The endogenous variable is affected by other factors in the model. The exogenous variables are not affected by other factors.

2. Structural equation model assumptions

That is a structural equation model of the null hypothesis, hidden variables model covariance matrix and the covariance matrix. But in practice, the general difference between the covariance matrix to measure the sample covariance matrix estimation and estimation of model fitting degree[5].

3. The model form of structural equation model

The two model includes structural equation model. Are the measurement model and structural model. The measurement model by the latent variable and measurable variables. The main description of the relationship between the latent variable and measurable variables. Structural model by the latent variables. Reflect the causal relationship between the latent variables. The following measurement model[6]:

$$X = \Lambda_x \xi + \delta \quad Y = \Lambda_y \eta + \varepsilon \quad (1)$$

In formula (1) X is the observation variable of ξ ; Y is the observation variable of η ; δ and ε are residual; Λ_x and Λ_y are factor loading matrix.

The following is the form of structural equation :

$$\eta = B\eta + \Gamma\xi + \zeta \quad (2)$$

In formula (2), η is the endogenous latent variable, ξ is exogenous latent variables; ζ is the residual, B and Γ are endogenous latent variable coefficient matrix and exogenous latent variables. η represents the endogenous latent variable number; ξ express exogenous latent variables as endogenous latent number; B variable coefficient matrix, describing the effects of endogenous variables as exogenous latent variables, Γ is the coefficient matrix, describe the effects of exogenous latent variables are endogenous latent variables.

An empirical study on College Students' satisfaction

1. Established structural equation model

The general view is that evaluation generally originated from the satisfaction degree of the customers satisfaction evaluation in Colleges and universities. The first customer satisfaction evaluation model is founded from Professor Fornell of University of Michigan in 1989 America. Later, after continuous development. Many countries have put forward their own model. The general view is America model of customer satisfaction index in 1994 was the most widely applied. Based on the American satisfaction index model. Established in Chinese satisfaction evaluation model. As shown in figure 1.

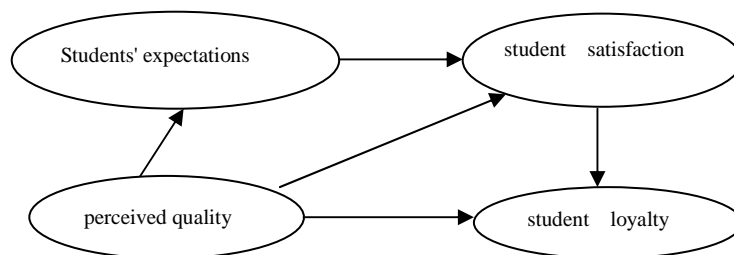

Figure 1.China the satisfaction evaluation model

In recent years, research on every consumer satisfaction are gradually weak. Therefore, this paper will combine the loyalty and satisfaction. According to the causal relationship between student expectations, perceived quality, student satisfaction, student loyalty, the satisfaction evaluation model. Put forward a structure variable hypothesis.

H1: students perceived quality increases will cause the student satisfaction.

H2: student satisfaction will lead to improved student loyalty.

H3: students are expected to improve will cause the student satisfaction.

H4: students perceived quality increases will cause the student is expected to improve.

H5: students perceived quality increases will cause the student loyalty.

2. Questionnaire design

After the establishment of a structural equation model of college student satisfaction. According to the relationship between the latent variables and observed variables, in this paper, referencing to the relevant literature and the Bollen in 1989 to the structure equation model views. The questionnaire divide to seven scales. And established evaluation system specific as shown in table 1.

Table 1. College student satisfaction evaluation system

	Latent variable	The observed variables
The satisfaction evaluation index	The students expected	The pre-school, understanding of teaching level
		The pre-school, understanding of visibility
		The pre-school, awareness of employment
	Perceived quality	Relationship between teachers and students
		School teachers' teaching ability
		The whole school hardware level
	Satisfaction	The humanization of school rules and policies
On the teaching activities of satisfaction		
The infrastructure of satisfaction		
Loyalty	Students to remain in school	
	Recommend the school to others	
	Choose again, still choose this school	

This questionnaire adopts electronic questionnaire to collect. Received a total of 300 questionnaires. The 124 boys. 176 girls. In them, fresher 76. sophomore 120. junior 80. senior 24.

Analysis of structural equation model

1. Confirmatory factor analysis (CFA)

Table 2. Underlying dimensions analysis table

			LNSTD	S.F	C.R	P	std	SMC	1-SMC	CR	AVE
SF3	<---	SF	1				0.711	0.506	0.494		
SF2	<---	SF	1.247	0.086	14.575	***	0.93	0.865	0.135	0.884	0.72
SE1	<---	SE	1.228	0.085	14.363	***	0.888	0.789	0.211		
SS1	<---	SS	1				0.706	0.498	0.502		
SS2	<---	SS	1.028	0.102	10.05	***	0.707	0.500	0.500	0.737	0.483
SS3	<---	SS	1.024	0.106	9.656	***	0.671	0.450	0.550		
SL1	<---	SL	1				0.905	0.819	0.181		
SL2	<---	SL	1.031	0.048	21.663	***	0.908	0.824	0.176	0.905	0.762
SL3	<---	SL	0.878	0.049	17.837	***	0.802	0.643	0.357		
SO3	<---	SO	1				0.667	0.445	0.555		
SO2	<---	SO	1.11	0.105	10.582	***	0.768	0.59	0.41	0.798	0.57
SO1	<---	SO	1.155	0.106	10.877	***	0.821	0.674	0.326		

According to Thomopson in 2004 proposed the structure equation model, should first analyze the measurement model, to ensure the correctness of the correct factors can measure model. In this paper, the measurement model of first-order confirmatory factor analysis. For the four aspect of the model: Students' expectation, perceived quality, satisfaction, loyalty, get the table 2 as follows:

Among them, SS is the student satisfaction, SQ is perceived quality, SE is the student expectations, SL is the student loyalty.

According to the table can know. Factor loading all between 0.67 and 0.93, and very significant. Composite reliability CR between 0.737 and 0.905. Multiple correlation coefficient square between 0.483 and 0.72. Meet the Hair (2009) and Fornell (1981), Larcker three standards: the factor loading greater than 0.5. The reliability of CR is greater than 0.6. Multiple correlation coefficient square more than 0.5. This paper studies the model of multiple correlation coefficient square except loyalty is slightly lower than 0.5, the rest are in line with the conditions. Can think of four aspects has convergent validity.

2. Significant test path coefficients of the student satisfaction model

Table 3. Latent variable coefficient estimate table

			Estimate	S.E.	C.R.	P	Label
SE	<---	SQ	.541	.088	6.173	***	par_1
SS	<---	SQ	.613	.097	6.304	***	par_2
SS	<---	SE	.317	.069	4.577	***	par_4
SL	<---	SQ	.154	.133	1.157	.247	par_3
SL	<---	SS	.640	.128	5.014	***	par_5

Table 4. Results of variance estimation

	Estimate	S.E.	C.R.	P	Label
SQ	.538	.091	5.928	***	var_14
Y1	.575	.087	6.605	***	var_15
Y2	.309	.063	4.931	***	var_16
Y3	.614	.073	8.404	***	var_17
e1	.718	.065	10.962	***	var_18
e2	.179	.041	4.315	***	var_19
e3	.298	.045	6.612	***	var_20
e4	.703	.077	9.142	***	var_21
e5	.739	.081	9.128	***	var_22
e6	.896	.092	9.688	***	var_23
e7	.221	.034	6.553	***	var_24
e8	.225	.035	6.367	***	var_25
e9	.426	.042	10.113	***	var_26
e10	.670	.066	10.081	***	var_27
e11	.461	.056	8.285	***	var_28
e12	.346	.051	6.743	***	var_29

Whether the parameter test model estimation has statistical significance, the general is a significant test on the load factor. The table of C.R. values (t statistic) or the p value analysis. When the p value is less than 0.05, can be considered that the path coefficients in the 95% confidence interval and zero exist significant differences. There is no reason to believe that the path coefficient is zero. Refuse to path for the original hypothesis of zero. According to the C.R. values in Table 2, 3, P only perceived quality to the loyalty of students of 4 values greater than 0.05. Can not refuse path regression coefficient is the original hypothesis of zero; but the analysis on the other path, C.R. values were significantly. This suggests the existence of strong correlation between.

Table 5. The satisfaction evaluation model fitness comparison table

Adaptation degree index	Ideal targets	University degree of satisfaction index
χ^2	he smaller the better	121.560
χ^2/df	<3	2.481
GFI	>0.9	0.941
AGFI	>0.9	0.906
RMSEA	<0.08	0.071
TLI	>0.9	0.949
IFI	>0.9	0.962
CFI	>0.9	

3. College students satisfaction model fitness analysis

For a good model, in general there will be a good fit. Fit better illustrate the covariance matrix and the sample matrix of structural equation model is more close to. More accepting the null hypothesis. This paper selects Schreiber, Stage, King, Nora, Barlow (2006), Schreiber (2008), Jackson Gillasyp, Andpurc-Stephenson (2009) about the fitness

of the opinion. Based on χ^2/df , the matching fit degree (GFI), adjusted to fit (AGFI), average root mean square (RMSEA) approximation error non reference fit (NNFI), incremental fit (IFI), the whole of the structural equation model goodness of fit test. The specific numerical fit condition and university student satisfaction model are shown in table 5.

From the table 5 we can see that the student satisfaction, evaluation model established by this research. Having a better fit. Objective response to the actual situation of samples.

CONCLUSION

Structural equation model constructed from Figure 2, each standard deviation increase in perceived quality. Will lead to 0.21 standard deviation is expected to improve students. A one standard deviation increase students' expectations, the increase will bring 0.32 standard deviations of the student satisfaction. Each standard deviation increase the perceived quality of indirect will bring the 0.1472 standard deviations of the student satisfaction. This is lower than the direct effect of satisfaction on the perceived quality of the students. Similarly we can know, lower than its indirect effect through the direct effect of perceived quality to improve student loyalty. This means used in the premise of other conditions are not changed, will be less than the higher education quality brought about by the student satisfaction through improving the publicity brought about by the student satisfaction effect. Although improving teaching quality in surface to enhance the loyalty of students is relatively low, but brought about through the intermediary of the satisfaction of students' loyalty is relatively large.

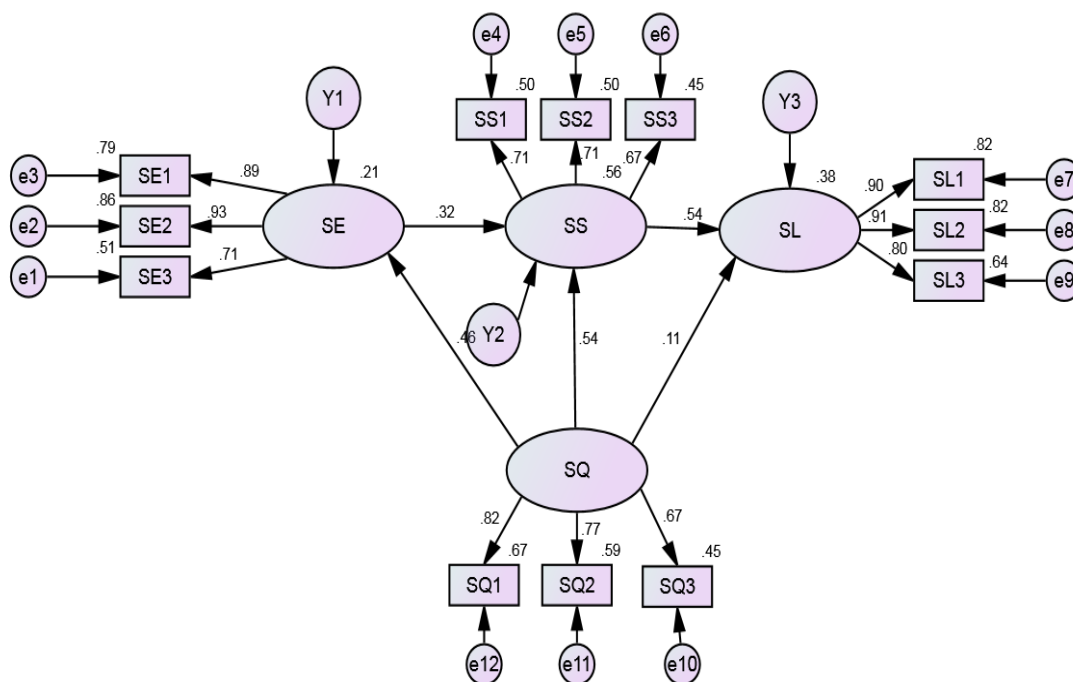

Figure 2. College student satisfaction evaluation model (Standardization)

Through the experiment, the statistical results of the student satisfaction model test results based on structural equation models presented in this paper truly matches the Chinese software testing center. Fully demonstrate the effectiveness of the model.

This study shows that, the relevant institutions in university construction, should pay more attention to the infrastructure, the quality of teachers and so on perceived quality of. Should not be concerned with advertising propaganda and invest a lot of resources in the University rankings. From the practical point of view on improving the overall quality of University education. To improve the students' satisfaction. To improve students' loyalty, get more of the students, and promote the development of Chinese education.

Acknowledgements

This paper is funded by National Education Science the Twelfth Five-year Plan for 2011 Ministry of Education Key Issues<Student Satisfaction Survey of Higher Education Services>(No.DIA110262).

REFERENCES

- [1] Zhang Jie; Tan Jiandan. *Research on higher education*, **2013**,1,9-22.
- [2] Lin Zhao;Shi Jinghuan;Wang Peng; Wang Wen; Xu sweet. Education in Tsinghua University, **2012**,5,19-32
- [3] Lu Genshu. Journal of Xi'an Jiao Tong University study undergraduate courses: Social Science Edition, **2013**,2,96-103.
- [4] Qiu Haozheng. *Journal of quantitative research*, **2011**, 3,6-16
- [5] ML Wu . Structural equation model of AMOS, Operation and application of the press of Chongqing University, Chongqing,**2010**, 10-37.
- [6] DH Yi. The method of structural equation model , Operation and application of the press of Renmin University of China, Beijing,**2009**,10-12.
- [7] Oliver;R. L. *Journal of Marketing*,**1999**,63,33-44.
- [8] Bollen;Kenneth A.John Wiley&Sons,**1989**,3,24-34.
- [9]Thompson;Bruce.Exploratory and confirmatory factor analysis,Understanding concepts and applications, American Psychological Association , **2004**,89-100
- [10]Schreiber, J.B.*Administrative Pharmacy* ,**2008**,4,83-97.
- [11] Jackson D.L.; Gillaspay J.A.;Purc-Stephenson R. *Psychological methods*, **2009**,14,6-23.